



## Pressure sensors

### C38 series

|                       |                                  |
|-----------------------|----------------------------------|
| <b>Series/Type:</b>   | <b>Gauge pressure sensor die</b> |
| <b>Ordering code:</b> | <b>B58601E38**B650</b>           |
| <b>Date:</b>          | 2016-09-02                       |
| <b>Version:</b>       | 2                                |

© EPCOS AG 2015. Reproduction, publication and dissemination of this publication, enclosures hereto and the information contained therein without EPCOS' prior express consent is prohibited.

EPCOS AG is a TDK Group Company.

### Applications

- Industrial
- Automotive
- Medical

### Features

- Piezoresistive MEMS technology
- Small dimensions: 1.65 × 1.65 mm
- Square diaphragm
- Measured media (back side):  
Non-aggressive gases and fluids.  
Unsuitable for substances which react with glass or silicon.
- Wheatstone bridge with mV output, ratiometric to supply voltage
- Rated pressure ranges 1.6 up to 40 bar
- Outstanding long-term stability

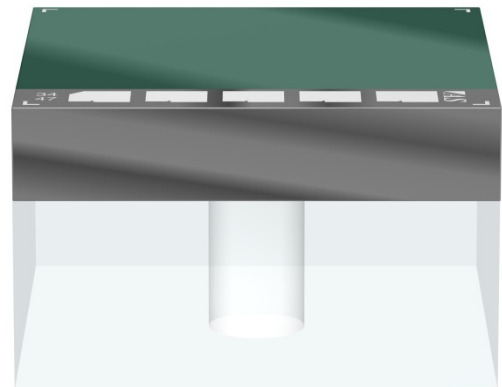

### Delivery mode

- Tape

### Dimensional drawings

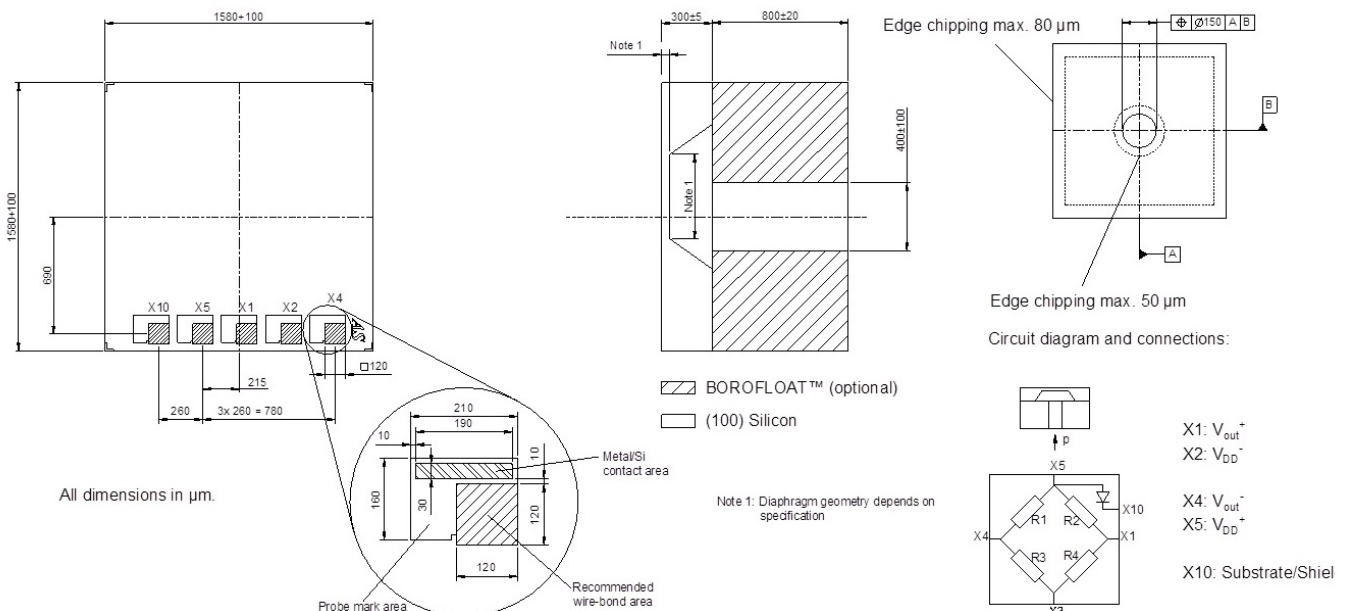

**Technical data**
**Absolute maximum ratings**

| Parameter                   | Symbol      | Conditions                   | Min. | Typ. | Max. | Unit  |
|-----------------------------|-------------|------------------------------|------|------|------|-------|
| <b>Supply voltage</b>       |             |                              |      |      |      |       |
| Maximum supply voltage      | $V_{DD}$    | Without damage <sup>1)</sup> |      |      | 10   | V     |
| <b>Temperature ranges</b>   |             |                              |      |      |      |       |
| Operating temperature range | $T_a$       | <sup>2)</sup>                | -40  |      | 135  | °C    |
|                             |             | For t <15 min                | -40  |      | 140  | °C    |
| Storage temperature range   | $T_{st}$    | <sup>3)</sup>                | -40  |      | 150  | °C    |
| <b>Pressure ranges</b>      |             |                              |      |      |      |       |
| Operating pressure ranges   | $p_r$       | Gauge pressure <sup>4)</sup> | 10   |      | 25   | bar   |
| Over pressure               | $p_{ov}$    | Gauge pressure <sup>5)</sup> | 3    |      |      | $p_r$ |
| Burst pressure              | $p_{berst}$ | Gauge pressure <sup>6)</sup> | 5    |      |      | $p_r$ |

**Electrical specifications**

| Parameter   | Symbol        | Conditions             | Min.           | Typ.  | Max. | Unit                             |
|---|---------------|------------------------|----------------|-------|------|----------------------------------|
| <b>Supply voltage / bridge resistance</b>                           |               |                        |                |       |      |                                  |
| Operating supply voltage  | $V_{DD}$      | <sup>7)</sup>          | 1.0            |       | 5.0  | V                                |
| Total bridge resistance   | $R_s$         | @ 25 °C <sup>8)</sup>  | 3.4            | 4.0   | 4.6  | k $\Omega$                       |
| Temperature coefficient of total bridge resistance                  | $\alpha_{Rs}$ | @ 25 °C <sup>9)</sup>  | 2.0            | 2.3   | 2.7  | 10 <sup>-3</sup> /K              |
|   | $\beta_{Rs}$  |                        | 0              | 6     | 8    | 10 <sup>-6</sup> /K <sup>2</sup> |
| <b>Output signal @ <math>V_{DD} = 5 V</math></b>                    |               |                        |                |       |      |                                  |
| Offset  | $V_o$         | @ 25 °C <sup>10)</sup> | -25            |       | +25  | mV                               |
| Sensitivity   | S             | @ 25 °C <sup>13)</sup> | See next table |       |      | mV/bar                           |
| Temperature coefficient of offset                                   | $TCV_0^-$     | Unglued <sup>11)</sup> | See next table |       |      | $\mu V/VK$                       |
|   | $TCV_0^+$     |                        | See next table |       |      | $\mu V/VK$                       |
| Temperature coefficient of the sensitivity                          | $\alpha_s$    | @ 25 °C <sup>15)</sup> | -2.5           | -2.2  | -1.9 | 10 <sup>-3</sup> /K              |
|   | $\beta_s$     |                        | 0              | 5     | 8    | 10 <sup>-6</sup> /K <sup>2</sup> |
| Pressure hysteresis   | $p_{Hys}$     | <sup>16)</sup>         | -0.1           |       | 0.1  | % FS <sup>12)</sup>              |
| <b>Long-term stability (Full scale normal output FSON = 120 mV)</b> |               |                        |                |       |      |                                  |
| Temperature hysteresis of offset                                    | $THV_0$       | <sup>17)</sup>         | -0.2           | ±0.1  | 0.2  | % FSON                           |
| Temperature cycle drift of offset                                   | $TCDV_0$      | <sup>17)</sup>         | -0.1           | ±0.05 | 0.1  | % FSON                           |
| High temperature drift of offset                                    | $HTDV_0$      | <sup>17)</sup>         | -0.25          | ±0.1  | 0.25 | % FSON                           |
| Long term stability of offset                                       | $LTSV_0$      | <sup>17)</sup>         | -0.3           | 0.15  | 0.3  | % FSON                           |

**Operating pressures and ordering codes**

| Parameter @ 25 °C, V <sub>DD</sub> = 5 V        | Symbol                        | Typ.                      | Typ.                      | Units               |
|---|-------------------------------|---------------------------|---------------------------|---------------------|
| Operating pressure <sup>4)</sup>                | p <sub>r</sub>                | 10                        | 25                        | bar                 |
| Temperature coefficient of offset [min/typ/max] | TCV <sub>0</sub> <sup>-</sup> | -12/0/12                  | -12/0/12                  | μV/VK               |
|   | TCV <sub>0</sub> <sup>+</sup> | -6/0/6                    | -6/0/6                    | μV/VK               |
| Nonlinearity <sup>14)</sup> [typ/max]           | L                             | ±0.2/±0.3                 | ±0.2/±0.3                 | % FS <sup>12)</sup> |
| Sensitivity <sup>13)</sup> [min/typ/max]        | S                             | 1.4/2/3.3                 | 0.8/1/1.2                 | mV/V/bar            |
| Product type                                    |                               | AER 10.00 C38/1 F00 G08 N | AER 25.00 C38/1 F00 G08 N |                     |
| Ordering code                                   |                               | B58601E3815B650           | B58601E3845B650           |                     |

Other operating pressures upon request.

## Symbols and Terms

- 1) **Maximum power supply  $V_{DD}$**   
This is the maximal allowed voltage, which may be applied to the piezoresistive bridge circuit without damage.
- 2) **Operating temperature range  $T_a$**   
This is the operating Temperature range  $T_{a,min}$  to  $T_{a,max}$ . Because most of the sensor parameters depend on assembling conditions like gluing, wire bonding etc, the die has to be tested over the operating temperature range by the customer fully assembled. For design verification and process control samples, mounted in AK transducer package (AK2 series) are tested over the temperature range of  $T_{min}$  to  $T_{max}$ .
- 3) **Storage temperature range  $T_{st}$**   
If the pressure sensor dies are stored in the temperature range  $T_{st,min}$  to  $T_{st,max}$  without applied voltage power supply, this will not affect the performance of the pressure sensor dies.
- 4) **Operating pressure range  $p_r$**   
In the operating pressure range 0 to  $p_{r,max}$  the pressure sensor die output characteristic is as defined in this specification.
- 5) **Over pressure  $p_{ov}$**   
Pressure cycles in the pressure range 0 to  $p_{ov}$  do not affect the performance of the pressure sensor dies.
- 6) **Burst pressure  $p_{berst}$**   
Up to the burst pressure  $p_{berst}$  the diaphragm of the sensor die will not be destroyed mechanically. This parameter is tested at room temperature on samples mounted on an aluminium socket by increasing the applied pressure until the diaphragm is destroyed. Since the burst pressure depends on several assembling conditions, this parameter has to be verified by the customer with his assembling possibilities.
- 7) **Operating power supply  $V_{DD}$**   
The pressure sensor parameters are defined for a power supply voltage of  $V_{DD} = 5\text{ V}$ . In the operating power supply voltage range  $V_{DD,min}$  to  $V_{DD,max}$  the ratiometric parameters  $r(V_{DD})$  like sensitivity, offset voltage and the temperature coefficient of the offset voltage are defined by:

$$r(V_{DD}) = r(5[V]) \frac{V_{DD}}{5[V]}$$

- 8) **Total bridge resistance  $R_S$**   
The total bridge resistance is defined between pad X5 and X2, (see the dimensional drawing in this data sheet) of the closed piezoresistive bridge circuit. The total bridge resistance is in a good approximation the output impedance of the piezoresistive bridge circuit. This parameter is tested completely on a wafer (wafer level test measurement).
- 9) **Temperature coefficients of resistance  $\alpha_{R_S}$  and  $\beta_{R_S}$ :**  
The temperature coefficients of resistance are tested for design verification on samples, mounted on AK transducer package (AK2 series) over the temperature range  $T_{min}$  to  $T_{max}$  with  $T_R = 25\text{ }^\circ\text{C}$ .  
The temperature coefficients of first and second order are defined with the polynomial:

$$R_S(T) = R_S(T = 25\text{ }^\circ\text{C}) \left[ 1 + \alpha_{R_S} (T - 25\text{ }^\circ\text{C}) + \beta_{R_S} (T - 25\text{ }^\circ\text{C})^2 \right]$$

The coefficients  $\alpha_{R_S}$  and  $\beta_{R_S}$  are calculated using the three measurement points of  $R_S(T)$  at  $T_{meas,min}$ ,  $T_R$  and  $T_{meas,max}$ .

- 10) **Offset voltage  $V_0$**   
The offset voltage  $V_0$  is the output voltage  $V_{out}(p = 0\text{ bar gauge})$  at zero gauge pressure and for a bridge voltage power supply  $V_{DD} = 5\text{ V}$ . This parameter is tested completely on a wafer (wafer level test measurement).  
Since the offset voltage depends on several assembling conditions, this parameter has to be verified by the customer with his assembling possibilities.
- 11) **Temperature coefficient of offset voltage  $TCV_0$**   
The temperature coefficients of offset voltage are defined for a bridge voltage power supply  $V_{DD} = 5\text{ V}$ .  
These parameters strongly depend on assembly conditions like gluing, wire bonding etc.  
The temperature coefficients of offset voltage are tested for design verification on samples, mounted on AK transducer package (AK2 series) over the temperature range  $T_{min}$  to  $T_{max}$ .  
Therefore  $TCV_{0+}$  and  $TCV_{0-}$  are defined for the measurement temperature range by:

$$TCV_{0+} = \frac{V_0(T_{max}) - V_0(25^\circ\text{C})}{T_{max} - 25^\circ\text{C}} \quad TCV_{0-} = \frac{V_0(T_{min}) - V_0(25^\circ\text{C})}{T_{min} - 25^\circ\text{C}}$$

Since the  $TCV_0$  depends on several assembling conditions, this parameter has to be verified by the customer with his assembling possibilities.

**12) Full scale value FS**

$$FS = V_{out}(p_{rmax}) - V_o$$

**13) Sensitivity S**

The sensitivity is defined for a bridge voltage power supply  $V_{DD} = 5\text{ V}$ . It can be determined by the formula:

$$S = \frac{V_{out}(p_{rmax}) - V_o}{p_{rmax}}$$

This parameter is tested for process control on samples, mounted on AK transducer package (AK2 series).

**14) Nonlinearity L**

This parameter may be influenced by assembly.

The nonlinearity is measured using the endpoint method. Assuming a characteristic, this can be approximated by a polynomial of second order, where the maximum is at  $p_x = p_{rmax}/2$ . The nonlinearity is defined at  $p_x = p_{rmax}/2$ , using the equation:

$$L = \frac{V_{out}(p_x) - V_o}{V_{out}(p_{rmax}) - V_o} - \frac{p_x}{p_{rmax}}$$

This parameter is tested for process control on samples, mounted on AK transducer package (AK2 series).

**15) Temperature coefficient of sensitivity  $\alpha_S$  and  $\beta_S$ :**

These parameters may be influenced by assembly.

The temperature coefficients of sensitivity are tested for design verification on samples, mounted on AK transducer package (AK2 series) over the temperature range  $T_{min}$  to  $T_{max}$  with  $T_R = 25\text{ °C}$ .

The temperature coefficients of first and second order are defined with the polynomial:

$$S(T) = S(T = 25\text{ °C}) \left[ 1 + \alpha_S(T - 25\text{ °C}) + \beta_S(T - 25\text{ °C})^2 \right]$$

The coefficients  $\alpha_S$  and  $\beta_S$  are calculated using the three measurement points of  $S(T)$  at  $T_{meas,min}$ ,  $T_R$  and  $T_{meas,max}$ .

**16) Pressure hysteresis pHys**

The pressure hysteresis is the difference between output voltages at constant pressure and constant temperature while applying a pressure cycle with pressure steps of  $p_{r,min}$ ,  $p_1$ ,  $p_2$ ,  $p_3$ ,  $p_{r,max}$ ,  $p_3$ ,  $p_2$ ,  $p_1$ ,  $p_{r,min}$ :

$$pHys = \frac{V_{out,2}(p_k) - V_{out,1}(p_k)}{FS}$$

With  $k = \text{min}, 1, 2, 3, \text{max}$ . The pressure steps are:  $p_{rmin} = 0$ ,  $p_1 = 0.25 \cdot p_{r,max}$ ,  $p_2 = 0.5 \cdot p_{r,max}$ ,  $p_3 = 0.75 \cdot p_{r,max}$ ,  $p_{r,max}$ .

This parameter is tested for design verification on samples, mounted on AK transducer package (AK2 series). Since the pHys depends on several assembling conditions, this parameter has to be verified by the customer with his assembling possibilities.

**17) Reliability data**

For long-term stability of offset voltage  $LTSV_0$  please refer to the defined Aktiv Sensor's standard AS100001 in chapter "Reliability data" on the internet. Since the  $LTSV_0$  depends on several assembling conditions, this parameter has to be verified by the customer with his assembling possibilities.

## Cautions and warnings

### Storage (general)

All pressure sensors should be stored in their original packaging. They should not be placed in harmful environments such as corrosive gases nor exposed to heat or direct sunlight, which may cause deformations. Similar effects may result from extreme storage temperatures and climatic conditions. Avoid storing the sensor dies in an environment where condensation may form or in a location exposed to corrosive gases, which will adversely affect their performance. Plastic materials should not be used for wrapping/packing when storing or transporting these dies, as they may become charged. Pressure sensor dies should be used soon after opening their seal and packaging.

### Operation (general)

Media compatibility with the pressure sensors must be ensured to prevent their failure. The use of other media can cause damage and malfunction. Never use pressure sensors in atmospheres containing explosive liquids or gases.

Ensure pressure equalization to the environment, if gauge pressure sensors are used. Avoid operating the pressure sensors in an environment where condensation may form or in a location exposed to corrosive gases. These environments adversely affect their performance.

If the operating pressure is not within the rated pressure range, it may change the output characteristics. This may also happen with pressure sensor dies if an incorrect mounting method is used. Be sure that the applicable pressure does not exceed the overpressure, as it may damage the pressure sensor.

Do not exceed the maximum rated supply voltage nor the rated storage temperature range, as it may damage the pressure sensor.

Temperature variations in both the ambient conditions and the media (liquid or gas) can affect the accuracy of the output signal from the pressure sensors. Be sure to check the operating temperature range and thermal error specification of the pressure sensors to determine their suitability for the application.

Connections must be wired in accordance with the terminal assignment specified in the data sheets. Care should be taken as reversed pin connections can damage the pressure transmitters or degrade their performance. Contact between the pressure sensor terminals and metals or other materials may cause errors in the output characteristics.

### Design notes (dies)

This specification describes the mechanical, electrical and physical requirements of a piezoresistive sensor die for measuring pressure. The specified parameters are valid for the pressure sensor die with pressure application either to the front or back side of the diaphragm as described in the data sheet. Pressure application to the other side may result in differing data. Most of the parameters are influenced by assembly conditions. Hence these parameters and the reliability have to be specified for each specific application and tested over its temperature range by the customer.

### Handling/Mounting (dies)

Pressure sensor dies should be handled appropriately and not be touched with bare hands. They should only be picked up manually by the sides using tweezers. Their top surface should never be touched with tweezers. Latex gloves should not be used for handling them, as this will inhibit the curing of the adhesive used to bond the die to the carrier. When handling, be careful to avoid cuts

caused by the sharp-edged terminals. The sensor die must not be contaminated during manufacturing processes (gluing, soldering, silk-screen process).

The package of pressure sensor dies should not be opened until the die is mounted and should be closed after use. The sensor die must not be cleaned. The sensor die must not be damaged during the assembly process (especially scratches on the diaphragm).

### Storage conditions

Used materials for storage should be ESD protective according JESD625, non-outgassing, and chemically stable. Furthermore the following storage conditions should be preserved:

1. Storage in cabinets (if shipment package is opened):
  - a. Atmosphere: inert gas, dry air or dry nitrogen
  - b. Temperature range (in cabinet):  $20\pm 3$  °C
  - c. Relative humidity range (in cabinet): <40%
  - d. Particle count (in cabinet): Class 6 per ISO 14644:1999 (equivalent FED STD 209E Class 1000)
  - e. Shelf life under these conditions: 24 months for deliveries in trays
  - f. Shelf life under these conditions: 12 months for deliveries on tape
2. Storage in containers (if shipment package is sealed):
  - a. Sealed as delivered or backfilled with inert gas, dry air or dry nitrogen and re-sealed
  - b. Temperature range:  $20\pm 3$  °C
  - c. Relative humidity range: <50%
  - d. Particle count (during backfill): Class 6 per ISO 14644:1999 (equivalent FED STD 209E Class 1000)
  - e. Shelf life under these conditions: 12 months for deliveries in trays
  - f. Shelf life under these conditions: 6 months for deliveries on tape

This listing does not claim to be complete, but merely reflects the experience of EPCOS AG.

### Display of ordering codes for EPCOS products

The ordering code for one and the same EPCOS product can be represented differently in data sheets, data books, other publications, on the EPCOS website, or in order-related documents such as shipping notes, order confirmations and product labels. **The varying representations of the ordering codes are due to different processes employed and do not affect the specifications of the respective products.** Detailed information can be found on the Internet under [www.epcos.com/orderingcodes](http://www.epcos.com/orderingcodes)



## Important notes

The following applies to all products named in this publication:

1. Some parts of this publication contain **statements about the suitability of our products for certain areas of application**. These statements are based on our knowledge of typical requirements that are often placed on our products in the areas of application concerned. We nevertheless expressly point out **that such statements cannot be regarded as binding statements about the suitability of our products for a particular customer application**. As a rule, EPCOS is either unfamiliar with individual customer applications or less familiar with them than the customers themselves. For these reasons, it is always ultimately incumbent on the customer to check and decide whether an EPCOS product with the properties described in the product specification is suitable for use in a particular customer application.
2. We also point out that **in individual cases, a malfunction of electronic components or failure before the end of their usual service life cannot be completely ruled out in the current state of the art, even if they are operated as specified**. In customer applications requiring a very high level of operational safety and especially in customer applications in which the malfunction or failure of an electronic component could endanger human life or health (e.g. in accident prevention or life-saving systems), it must therefore be ensured by means of suitable design of the customer application or other action taken by the customer (e.g. installation of protective circuitry or redundancy) that no injury or damage is sustained by third parties in the event of malfunction or failure of an electronic component.
3. **The warnings, cautions and product-specific notes must be observed.**
4. In order to satisfy certain technical requirements, **some of the products described in this publication may contain substances subject to restrictions in certain jurisdictions (e.g. because they are classed as hazardous)**. Useful information on this will be found in our Material Data Sheets on the Internet ([www.epcos.com/material](http://www.epcos.com/material)). Should you have any more detailed questions, please contact our sales offices.
5. We constantly strive to improve our products. Consequently, **the products described in this publication may change from time to time**. The same is true of the corresponding product specifications. Please check therefore to what extent product descriptions and specifications contained in this publication are still applicable before or when you place an order. We also **reserve the right to discontinue production and delivery of products**. Consequently, we cannot guarantee that all products named in this publication will always be available. The aforementioned does not apply in the case of individual agreements deviating from the foregoing for customer-specific products.
6. Unless otherwise agreed in individual contracts, **all orders are subject to the current version of the "General Terms of Delivery for Products and Services in the Electrical Industry" published by the German Electrical and Electronics Industry Association (ZVEI)**.
7. The trade names EPCOS, Alu-X, CeraDiode, CeraLink, CeraPad, CeraPlas, CSMP, CSSP, CTVS, DeltaCap, DigiSiMic, DSSP, ExoCore, FilterCap, FormFit, LeaXield, MiniBlue, MiniCell, MKD, MKK, MotorCap, PCC, PhaseCap, PhaseCube, PhaseMod, PhiCap, PQSine, SIFERRIT, SIFI, SIKOREL, SilverCap, SIMDAD, SiMic, SIMID, SineFormer, SIOV, SIP5D, SIP5K, TFAP, ThermoFuse, WindCap are **trademarks registered or pending** in Europe and in other countries. Further information will be found on the Internet at [www.epcos.com/trademarks](http://www.epcos.com/trademarks).